

**cpc // Pumps**  
INTERNATIONAL

FORMERLY

**unitedpumps**  
OF CANADA LTD

Technology and Innovation  
Serving the Petroleum  
Industry



## CPC Pumps International Inc.

# Your Business Partner for the Hydrocarbon Industry

### **Product Range and Services.**

CPC Pumps International Inc. offers well established unique pump designs and production capabilities, building on our 50 plus years of industry specific experience.

With our extensive product range and unparalleled hydraulic performance coverage, we offer our customers engineered solutions for very demanding applications. Our unwavering focus on serving the market for centrifugal pumps designed and built to the latest American Petroleum Institute (API) standards has positioned us at the forefront of technological advancements. A number of our innovative products and features have served our customers in increasing plant reliability, and profitability.

CPC Pumps International, through its global presence, uses a dedicated team of sales and service personnel providing local professional support to end users. Our rapid response capabilities are setting the standard in our industry.

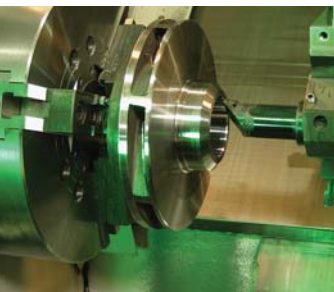

### **Engineering and Design**

Utilizing the latest computer aided-design and manufacturing tools, along with a talent pool of dedicated professionals, CPC Pumps International offers the skills and capabilities to rapidly bring new designs to market.

Mechanical design upgrades of older generation pumps combined with the ability to custom design drop-in replacement units has proven to be one of the most advantageous options to a variety of our customers, minimizing piping and system rework at site, and associated downtime.

Our “Can Do” attitude has been one of our defining assets, which has allowed our customers to benefit from substantial cost savings as a result of our unique capabilities and services.

### **Manufacturing and Testing**

Our new “state of the art” facility is located in Burlington, Ontario central to the Canadian manufacturing sector. Modern machinery and new test stand featuring a 30,000 gallon (114 m<sup>3</sup>) tank and motor drivers rated up to 4500 HP (3350 kw) are key components to our production capabilities. Variable frequency drives and customized transformers allow testing at any speed and virtually any voltage requirement.



CPC's experience in managing the complete production process for complex and highly variable requirements benefits our customers by achieving a high rate of on-time delivery and the ability to meet some of the most demanding fast track shipments.

Our production system is regulated by our Quality Assurance and Control programs, forming an integral aspect of our manufacturing cycle. This allows us to meet some of the most challenging requirements in the industry.



# MODEL HR/HOR (OH2)

Fully compliant with API 610 requirements

## Operating Parameters:

- Flow rate in excess of 15,000 USGPM (3,400 m<sup>3</sup>/h).
- Differential heads up to 1,200 FT (365 m).
- Temperatures up to 800 Deg. F (425 Deg. C)
- Standard Design Working Pressure of 725 PSIG (5,000 kpag).
- Higher pressure designs available, in excess of 1,450 PSIG (10,000 kpag).

## Standard Features:

- Widest hydraulic coverage in the industry.
- Application tailored hydraulic selections.
- 300# flange ratings, with end suction or top suction design casings.
- Available in all API 610 Table H.1 materials.
- Cast or fabricated impellers, for expanded hydraulic coverage.
- Close clearance metalized carbon throat bushing for optimal control of stuffing box environment.
- Rigid design shaft for minimal deflection to meet and exceed API 610 requirements.
- Cylindrical roller radial bearings for ample load carrying capability.



- Duplex angular contact 7300 series thrust bearings.
- Inpro/Seal bearing housing isolators.
- Heavy Duty baseplate, drip rim or drip pan designs.

## Optional Features:

- Semi-open Coke Crusher design, with wear plate.
- High pressure special casing design.
- Oil Flinger/Oil Ring/Purge Mist/Pure Oil lubrication of bearings.
- Oversized shafts and bearing housing arrangements.
- Fan/Heat-sink bearing housing cooling arrangement for operation at elevated temperatures, to eliminate the need for cooling water.
- Magnetic bearing housing isolators.
- Pre-grouted baseplates or non-grouted baseplates.
- Non-standard API 610 material available.

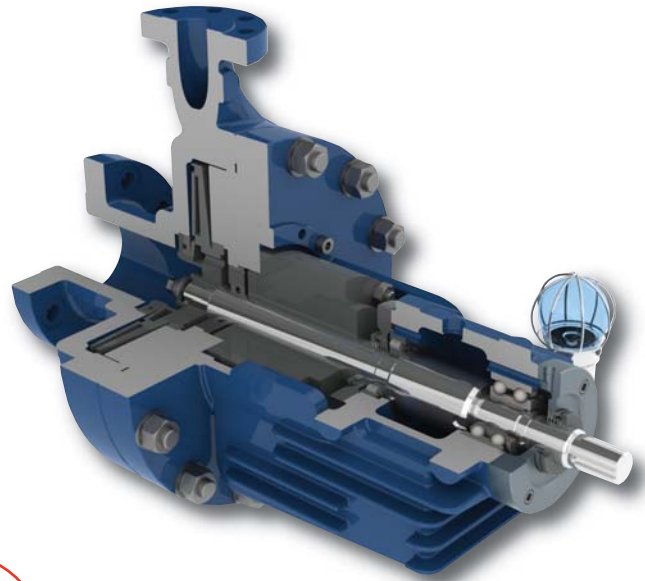

# MODEL VP-B (OH3)

Fully compliant to API 610 requirements

## Operating Parameters:

- Flow rate in excess of 8,000 USGPM (1,800 m<sup>3</sup>/h).
- Differential heads up to 1,200 FT (365 m).
- Temperatures up to 800 Deg. F (425 Deg. C).
- Standard Design Working Pressure of 725 PSIG (5,000 kpag).
- Higher pressure designs available, in excess of 1,450 PSIG (10,000 kpag).

## Standard Features:

- Widest Hydraulic coverage in the industry.
- Application tailored hydraulic selections.
- 300# flange ratings.
- Available in all API 610 Table H.1 materials.
- Cast or fabricated impellers, for expanded hydraulic coverage.
- Close clearance metalized carbon throat bushing, for optimal control of stuffing box environment.
- Rigid design shaft for minimal deflection meets and exceeds API 610 requirements.
- Cylindrical roller radial bearings for ample load carrying capability.
- Duplex angular contact 7300 series thrust bearings.
- Grease or pure mist lubrication.
- Inpro/Seal bearing housing closures.

## Optional Features:

- Semi-open Coke Crusher design, with wear plate.
- High pressure special casing design.
- Oversized shafts and bearing housing arrangements.
- Magnetic bearing housing isolators.
- Mounting plate.
- Soleplate.
- Thrust Pod (TP) design, for extra heavy thrust loads, with oil bath lubrication.
- Non-standard API 610 material available.



# MODEL VP-C (OH4)

Fully compliant to API 610 requirements

## Operating Parameters:

- Flow rate in excess of 8,000 USGPM (1,800 m<sup>3</sup>/h).
- Differential heads up to 1,200 FT (365 m).
- Temperatures up to 800 Deg. F (425 Deg. C).
- Standard Design Working Pressure of 725 PSIG (5,000 kpag).
- Higher pressure designs available, in excess of 3,750 PSIG (26,000 kpag).

## Standard Features:

- Widest hydraulic coverage in the industry.
- Application tailored hydraulic selections.
- 300# flange ratings.
- Available in all API 610 Table H.1 materials.
- Cast or fabricated impellers.
- Close clearance metalized carbon impeller bearing, a combination radial bearing/throat bushing.
- Rigid design shaft for minimal deflection meets and exceed API 610 requirements.
- Product lubricated impeller bearing.
- Tri-Link patented rigid spacer coupling, allowing removal of seal cartridge without disturbing driver.

## Optional Features:

- High pressure special casing design.
- Oversized shafts.
- Cartridge design Impeller bearing, for ease of maintenance.
- Air-Ex Stuffing Box spacer, for high temperature or Cryogenic applications.
- Mounting plate.
- Soleplate.



# MODEL VP-M (OH5)

Fully compliant to API 610 requirements

## Operating Parameters:

- Flow rate in excess of 8,000 USGPM (1,800 m<sup>3</sup>/h).
- Differential heads up to 1,200 FT (365 m).
- Temperatures up to 300 Deg. F (150 Deg. C).
- Standard Design Working Pressure of 725 PSIG (5,000 kpag).

## Standard Features:

- Widest hydraulic coverage in the industry.
- Application tailored hydraulic selections.
- 300# flange ratings.
- Available in all API 610 Table H.1 materials.
- Cast or fabricated impellers.
- Close clearance metalized carbon impeller bearing, a combination radial bearing/throat bushing.

## Optional Features:

- Mounting plate.
- Soleplate.



# MODEL HDR (BB2)

Single Stage Double Suction Pumps Fully compliant with API 610 requirements

## Operating Parameters:

- Flow rate in excess of 25,000 USGPM (5,700 m<sup>3</sup>/h).
- Differential heads up to 1,400 FT (425 m).
- Temperatures up to 800 Deg. F (425 Deg. C).
- Standard Design Working Pressure of 725 PSIG (5,000 kpag).
- Higher pressure designs available.

## Standard Features:

- Widest hydraulic coverage in the industry.
- Application tailored hydraulic selections.
- 300# or 600# flange ratings, with top suction top discharge design casings.
- Available in all API 610 Table H.1 materials.
- Close clearance metalized carbon throat bushing, for optimal control of stuffing box environment.
- Rigid design shaft for minimal deflection to meet and exceed API 610 requirements.

- Inpro/Seal bearing housing closures.
- Heavy duty baseplate, drip rim or drip pan designs.

## Optional Features:

- High pressure special casing design.
- Oversized shafts and bearing housing arrangements.
- Fan/Heat-sink bearing housing cooling arrangement for operation at elevated temperatures, to eliminate the need for cooling water.
- Magnetic bearing housing isolators.
- All bearing combination arrangements are available where suitable: Ball/Ball, Sleeve/Ball, Tilt Pad/Sleeve.

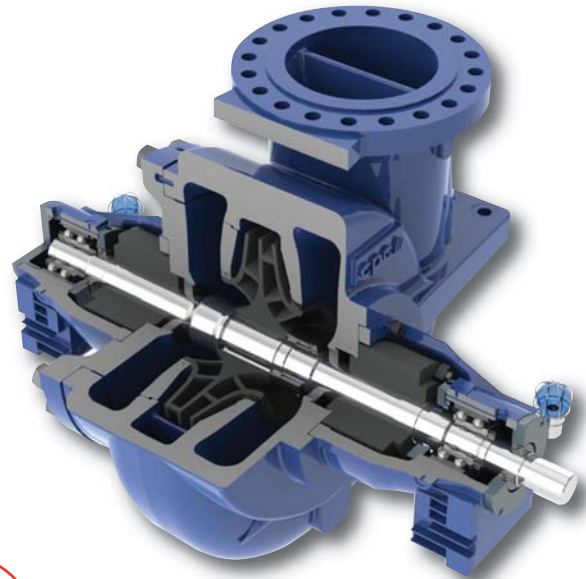

# MODEL H2R (BB2)

Two Stage Single or Double Suction First Stage Pumps Fully compliant with API 610 requirements

## Operating Parameters:

- Flow rate in excess of 6,200 USGPM (1,400 m<sup>3</sup>/h).
- Differential heads up to 2,800 FT (850 m).
- Temperatures up to 800 Deg. F (425 Deg. C).
- Standard Design Working Pressure of 725 PSIG (5,000 kpag).
- Higher pressure designs available.

## Standard Features:

- Widest hydraulic coverage in the industry.
- Application tailored hydraulic selections.
- 600/900/1500# flange ratings.
- Controlled compression fully confined gasket fit, case to cover.
- Available in all API 610 Table H.1 materials.
- Close clearance metalized carbon throat bushing for optimal control of stuffing box environment.
- Rigid design shaft for minimal deflection to meet and exceed API 610 requirements.
- Inpro/Seal bearing housing closures.

- Rigid cast Carbon steel bearing housings, with fins for improved heat dissipation.
- Heavy duty baseplate, drip rim or drip pan designs.

## Optional Features:

- High pressure special casing designs.
- Fan/Heat-sink bearing housing cooling arrangement for operation at elevated temperatures, to eliminate the need for cooling water.
- Magnetic bearing housing isolators.
- All bearing combination arrangements are available where suitable: Ball/Ball, Sleeve/Ball, Tilt Pad/Sleeve.

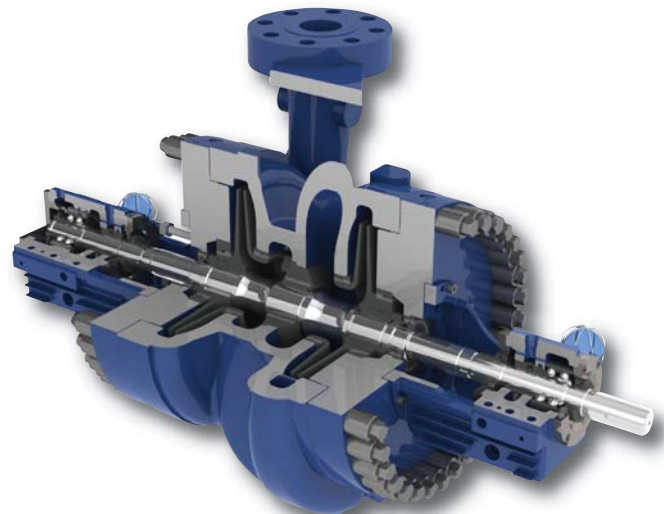

# MODEL HM (BB3)

Multistage Single or Double Suction First Stage Pumps Fully compliant with API 610 requirements



## Operating Parameters:

- Flow rate in excess of 4,400 USGPM (1,000 m<sup>3</sup>/h).
- Differential heads up to 5,600 FT (1,700 m).
- Temperatures up to 400 Deg. F (200 Deg. C).
- Standard Design Working Pressure of 2,250 PSIG (15,000 kpag).

## Standard Features:

- Wide hydraulic coverage.
- Application tailored hydraulic selections.
- 600/900/1500# flange ratings.
- Available in all API 610 Table H.1 materials.
- Hydraulically opposed impeller arrangement for thrust balancing.
- Axially split, precision milled parting flanges.
- Split case wear rings and center bushings for ease of maintenance.
- Integral balance line.
- Rigid design shaft for minimal deflection to meet and exceed API 610 requirements.
- Inpro/Seal bearing housing closures.
- Heavy Duty baseplate, drip rim or drip pan designs.

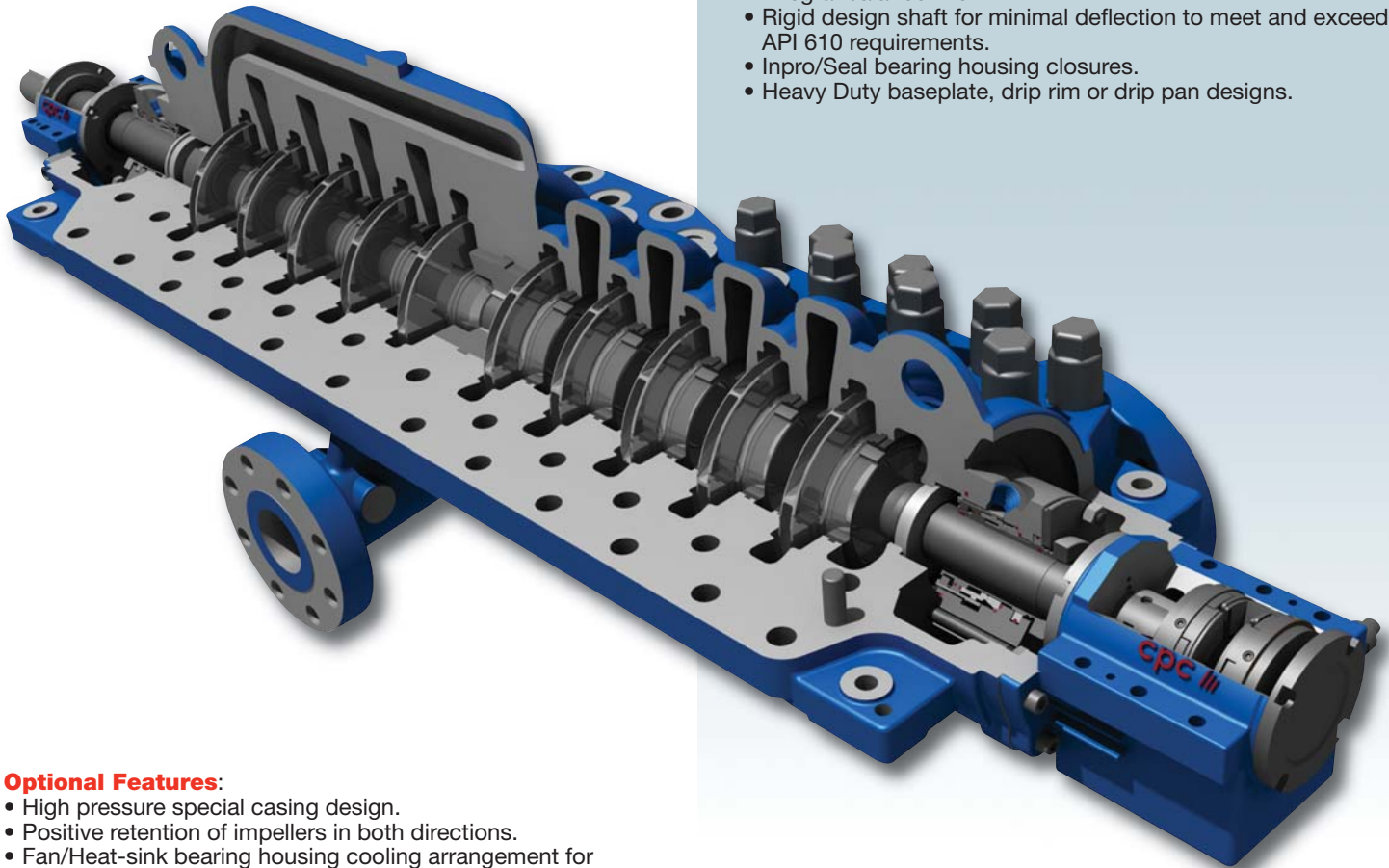

## Optional Features:

- High pressure special casing design.
- Positive retention of impellers in both directions.
- Fan/Heat-sink bearing housing cooling arrangement for operation at elevated temperatures, to eliminate the need for cooling water.
- Magnetic bearing housing isolators.
- All bearing combination arrangements are available where suitable: Ball/Ball, Sleeve/Ball, Tilt Pad/Sleeve.



## Sales / Service Locations

### **CANADA**

Toronto  
Montréal  
Calgary  
Vancouver

### **USA**

Houston, TX  
Dallas, TX  
Tyler, TX  
Alabama  
Florida  
California  
Louisiana  
Montana  
Wyoming  
North Dakota  
Washington  
Pennsylvania

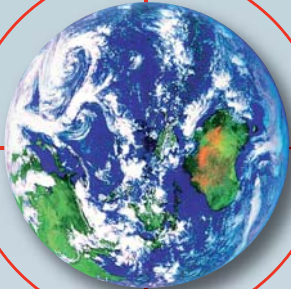

### **EUROPE / MIDDLE EAST**

Contact CPC Pumps International

### **ASIA PACIFIC**

Singapore  
China  
Taiwan  
Malaysia  
Indonesia  
Brunei  
India  
Pakistan  
South Korea  
Thailand  
Japan

### **For these and all other locations please contact**

CPC Pumps International at  
Phone: 1+289-288-4753 Fax: 1+289-288-4782  
sales@cpcpumps.com  
[www.cpcpumps.com](http://www.cpcpumps.com)